

INSTRUCTION MANUAL

**CAT. 87026-01, 87026-02, 87026-03,
87026-04, 87026-05, 87026-06,
87026-07, 87026-08**

**EMS MyBlock™ I & II Dry Bath,
Single and Dual Chambers**



Contents

Learn more about your Dry Bath.....	3
Features.....	3
Specifications.....	3
Ambient operating temperature.....	3
Technical data.....	3
Structure overview.....	3
Keypads.....	4
Display.....	4
Operation.....	4
Temperature and time setting.....	4
Timer operation (advanced).....	5
Temperature calibration.....	5
Calibration with a thermometer.....	5
Calibration with the external temperature probe.....	6
Temperature control by external sensor.....	8
Failure analysis and troubleshooting.....	8
Annex: Wiring diagram.....	9

Learn more about your Dry Bath!

The Dry Bath incubator is controlled by advanced software, which can be widely used for the preservation and reaction of sampled, the amplification of DNA, the pre-denaturation of the electrophoresis, blood serum coagulation and a variety of laboratory procedures and applications!

Features

- Large digital display of time and temperature
- Extremely accurate temperature control up to 105°C
- Built-in over-temperature protection
- In-lab calibration
- Plastic lid for enhanced precision and eliminating waste of energy
- Quick-Flip blocks available for a variety of tube sizes

Specifications

Ambient operating temperature

Ambient temperature: 5°C ~ 35°C

Relative humidity: ≤ to 70%

Power supply: AC115V or 230V, 50-60Hz

Technical data

Temperature range	Ambient (room temperature) +5°C ~ 105°C
Timer	Maximum 99 hr & 59 min
Temperature accuracy	≤ ± 0.3%
Temperature uniformity	≤ ± 0.1%
Heating time (20-105°C)	≤ 20 min
Block material	Aluminum
Power	120W (single)/240W (dual)
Fuse	250V 4A Φ 5 x 20
Dimensions (L x W x H)	7 x 10 x 5 in. / 18 x 25 x 13 cm (single) 6.3 x 14.5 x 5 in. / 16 x 36.5 x 13 cm (dual)
Warranty	2 years

Structure overview

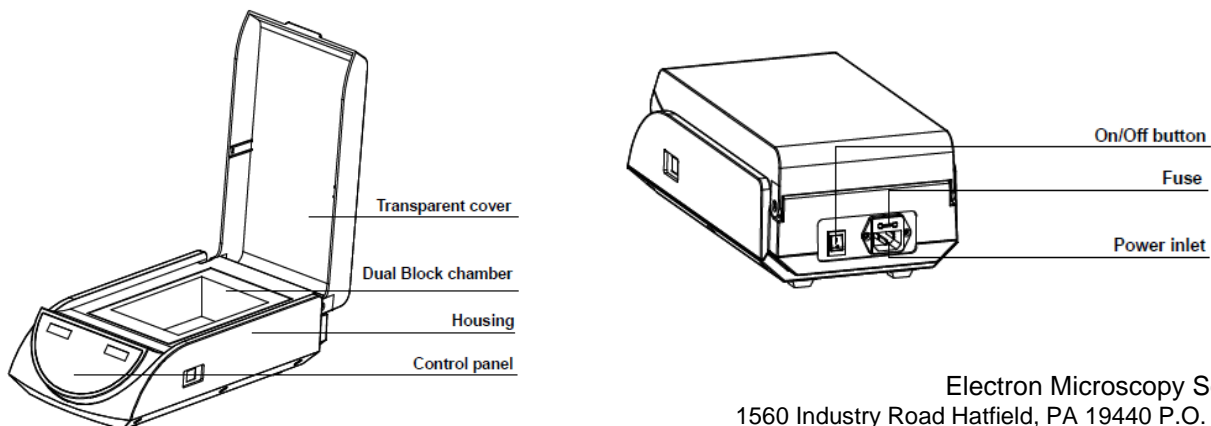

Electron Microscopy Sciences
1560 Industry Road Hatfield, PA 19440 P.O. Box 550
TEL: 215-412-8400 TOLL FREE: 1-800-523-5874 FAX: 215-412-8450
EMAIL: sgkcck@aol.com WEB: www.emsdiasum.com

Keypads

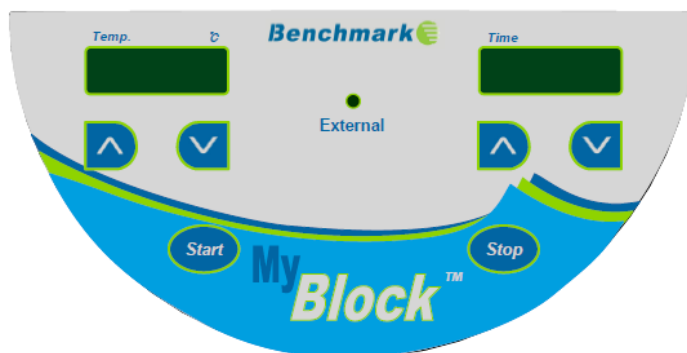





Display

- ▼ Down key: used in both time and temperature mode to decrease the setting
- ▲ Up key: used in both the time and temperature mode to increase the setting.
- Start** Start key: after the temperature and time setting is selected, press this key to start the timer
- Stop** Stop key: press this key to stop the timer

Operation

Temperature and time setting

1. Press the ON/OFF switch to power on the instrument. The instrument performs a self-test followed by an alarm to signal that the product is ready for use. 
2. After about 3 seconds, the temperature will automatically increase to the most recent setting. The values shown on the display are actual settings (real time temperature and time remaining). The example shows an actual temperature of 28.5°C and 35 minutes remaining. 
3. To adjust the set temperature, use the ▲ or ▼ keys to select the desired temperature (ex: 55.5). After 5 seconds, the temperature is stored and the instrument will begin heating. 
4. To set the time, press ▲ or ▼ keys to set the desired time (ex: 1 hr 20 min). After 5 seconds, the desired time is stored. 

NOTE: The timer will not begin unless the “Start/Stop” button has been pressed.

Timer operation (advanced)

The default setting of the instrument is designed so that the heater will continue to hold the set temperature even once time has expired and “oVEr” is showing on the time display. This setting can be adjusted so that the heater will shut down once time has expired. To adjust the advanced time setting, set the “Stop” key and hold it for 10 seconds. After 10 seconds, the display will show “OP:1” – use the ▲ or ▼ Key to select “OP:2”. The setting has now been changed and can be stored by pressing the “Start” key.

Temperature calibration

The temperature of the instrument has been calibrated prior to shipment. However, in the event that an adjustment to the calibration is required, the user can adjust the calibration with either a thermometer/thermocouple or with the optional external temperature probe, which is sold separately.

CAUTION! To ensure accuracy over a wide range of temperatures, the instrument is calibrated at two temperature points, both 40°C and 100°C.

Calibration with a thermometer

1. Power on the machine and ensure that the temperature on the display is less than 35°C.
2. Inject olefin or mineral oil into one of the block wells, and then put a thermometer/thermocouple into this well (make sure that the precision of the thermometer should be within 0.1C and it be fully submerged into the well). See figure below.

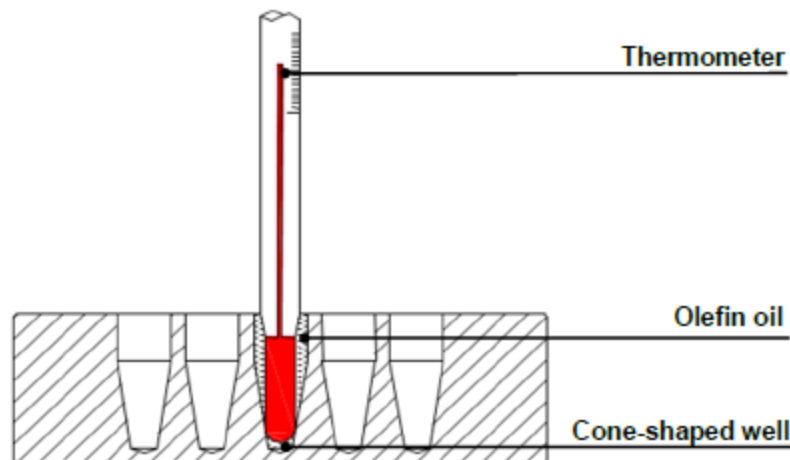

3. Press “Stop” key and the ▲ key simultaneously for 3 seconds—the bath enters into the temperature calibration interface. At this point “ Ad Jt ” is displayed, indicating entry into temperature calibration mode. The temperature displayed is current measured temperature and over time, it begins to rise to 40°C.

NOTE: it may take up to 30 minutes before a change on the display to 40°C is shown.

Once held constant at 40°C, the decimal digit begins to flash.



Please wait 20 minutes, then the user can read the value on the thermometer and use the up and down keys to match the temperature on the display to the value shown on the thermometer.

NOTE: It is important to allow 20 minutes for the temperature to equilibrate before making any adjustment to the temperature.



Ex: If the actual read out of thermometer is 39.6, modify the temperature to 39.6 by pressing ▲ or ▼ Then press “Start” to confirm the input value.

The 40°C calibration has now been completed and the dry bath begins the 100°C calibration.

4. Once the “Start button is pressed, the instruments will automatically begin to heat to 100°C. Once the 100°C is shown on the display (this may take up to 30 minutes) and held as constant, the decimal begins to flash. Please wait 20 minutes and then check the actual value from thermometer.

NOTE: It is important to allow 20 minutes for the temperature to equilibrate before making any adjustment to the temperature.

If the actual thermometer shows 101.5, modify the temperature display to 101.5 by pressing . Then press “Start” (▲ or ▼) in the input value.

NOTE: Pressing “Stop” and “ ▼ ” simultaneously during the temperature calibration indicates exiting the temperature calibration program. The adjustments will be cancelled and the changes will not take effect.

Calibration with the external temperature probe

1. Power on the machine. Before beginning the calibration, always ensure that the temperature on the display is less than 35°C.
2. Put external temperature probe into a block well.
3. Press “Stop” key and the “ ▲ ” key simultaneously and hold for 3 seconds. This will enter the temperature calibration mode with the external probe. “ EAdJ ” will be displayed, indicating entry into



external temperature calibration mode. The temperature displayed is the external probes current temperature and it will begin to rise to 40.0° automatically.

NOTE: It may take up to 30 minutes before a change on the display to 40.0°C is shown.

Once held at a constant 40.0°C, the decimal digit begins to flash.



NOTE: It is important to allow 20 minutes for the temperature to equilibrate before making any adjustment to the temperature.

After 20 minutes, press the “Stop” key to display the temperature value of the external probe. Ex: If the displayed value is 39.6°C.

Press “Stop” again (or wait for 6 seconds), then display shows

“ **Ad Jt** ”. The temperature can now be adjusted by pressing

“ ▲ or ▼ ” to match the measured value (ex: 39.6). Then press the “Start” key to confirm.



The 40° calibration has now been completed and the dry bath begins the 100°C calibration.

4. The instrument will then heat ▲ 100°C automatically. Once 100°C has been reached and held constant, the decimal point will begin to flash.

NOTE: It is important to allow 20 minutes for the temperature to equilibrate before making any adjustments to the temperature.

After 20 minutes, press the “Stop” key to show the actual readout of the external probe (ex: 101.5°C).



Press “Stop” again (or wait for 6 seconds), then display shows “ **Ad Jt** “. Now adjust the displayed temperature to the measured value (101.5) by pressing ▲ or ▼. Then press the “Start” key to confirm.

NOTE: Pressing “Stop” and ‘▼’ “ simultaneously during the temperature calibration indicates exiting the temperature calibration program. The procedure will be cancelled and the changes will have of no effect.

Temperature control by external sensor

1. Insert the external temperature probe into a well of the dry bath or directly into a sample tube.

2. Press and hold “Stop”, then simultaneously press and hold “ ▲ ” for 3 seconds—the external indicator light goes on to indicate that it has entered into the temperature control mode of the external sensor.

NOTE: After entering the external temperature control mode, the user can simultaneously press “Stop” and “ ▲ ” for 3 seconds to exit this mode. Upon exiting, the external indicator light will go off.

Failure analysis and troubleshooting

No.	Common problem	Possible cause	Action(s)
1	No display on the screen	No power on the main power plug Faulty fuse On/off button broken Other	Check power supply and plugged properly Change fuse Change button Contact supplier
2	The actual and displayed temperatures are quite different	Broken sensor or loose contact of the block	Contact the supplier
3	“OPEn” displayed, alarming “beep” “SHOr” displayed, alarming “beep” “HHHh” displayed, alarming “beep”	Sensor disconnect Sensor short-circuit Sensor broken, or block temperature is too high	Contact supplier Contact supplier Contact supplier
4	No heating	Sensor broken Heating tube broken	Contact supplier Contact supplier
5	Keys do not work	Faulty key	Contact supplier

Annex: Wiring Diagram—for reference only

