

**INSTRUCTIONAL MANUAL  
CAT. 72344 Series, 72347-12 and 72347-20  
SuperNuova™ Digital Top Stirring Plates**



**Electron Microscopy Sciences**  
P.O. Box 550  
1560 Industry Road Hatfield, PA 19440

Toll free: 1-800-523-5874  
Tel: 215-412-8400  
Fax: 215-412-8450

Web: [www.emsdiasum.com](http://www.emsdiasum.com)  
Email: [sgkcck@aol.com](mailto:sgkcck@aol.com)

## Safety Information

### Warning signals:



**Warning.** Indicates possibility of personal injury as well as reference to servicing by authorized personnel.



**Caution.** Indicates possibility of damage to equipment.



**Note.** Indicates pertinent facts and conditions. The SuperNuova™ hot plates are not explosion proof, therefore, if explosion proof materials are needed, contact Customer Service at 1-800-523-5874.



**Hot Surface.** Indicates possibility of personal injury should you come in contact with surfaces during use or for a period of time.

This product should only be used under the operating conditions explicitly stated in this instruction manual. We advise adhering to all safety procedures such as unplugging when not in use, for example. Authorized personnel using this product should be prepared and anticipate any problems. If over-temperature failure occurs, the top surface temperature could rise to the maximum temperature (300-450°C depending on the specifications of your model) and remain at that temperature indefinitely. Considering these conditions, the material being heated on the surface of the hotplate could reach excessive temperature levels.

## Warnings

### To avoid electrical shock

1. Electrical outlets should always be properly grounded, be of the correct voltage and current handling capacity.
2. Prior to maintenance and servicing, the power supply should always be disconnected.

### To avoid electrical shock

1. Avoid using the product near flammable materials and/or sources – doing so will result in fire or explosion. Please note that this product contains components that can ignite such material.
2. Use the utmost caution when heating volatile materials – top surface and element can reach the “Flash Point Temperature” of many chemicals. These hot plates are not explosion proof – fire and/or explosion can result.
3. Please keep the top surface clean. To clean, use a non-abrasive cleaner. Any spills involving alkali, hydrofluoric acids, or phosphoric acids may damage the top and lead to thermal failure. Should this occur, unplug the product and address the spills promptly. DO NOT, under any circumstances, immerse the product for cleaning.
4. If damage by etching, scratching, or chipping is present, replace the top immediately. Any damage to the top can break when in use.
5. DO NOT use metal foil on the hot play – this can block air flow, resulting in overheating.

**Electron Microscopy Sciences**  
P.O. Box 550  
1560 Industry Road Hatfield, PA 19440

Toll free: 1-800-523-5874

Tel: 215-412-8400

Fax: 215-412-8450

Web: [www.emsdiasum.com](http://www.emsdiasum.com)

Email: [sgkcck@aol.com](mailto:sgkcck@aol.com)

6. Be sure to check and tighten the removable cord, making sure that it is secure. If the cord becomes loose, it could become hot and/or spark, resulting in a potential fire hazard. Any cords that appear damaged in any way should be replaced immediately.
7. DO NOT remove or modify the grounded power plug – use ONLY properly grounded outlets to avoid a shock hazard.
8. ALWAYS use appropriate hand and eye protection when handling hazardous chemicals.
9. The gross weight of the items placed on top of the hot places SHOULD NOT exceed 35 pounds on the 10" x 10" models and 25 pounds on the 7" x 7" models.
10. "CAUTION-HOT TOP". The top plate of the unit can remain hot for some time after use, however, a "CAUTION-HOT TOP" light will remain on until the temperature cools to below 50°C.
11. DO NOT leave an active probe out of the fluid – this may cause uncontrollable heating of the fluid on the hot plate, unintentional boiling, or an explosion.
12. Localized heater element temperature can be significantly higher than the temperature indicated on the display. If flammable materials reach the internal element, fire could result.
13. NOTE that the exterior housing of the element will be hot during and after the time of use.
14. All servicing and maintenance should be referred to authorized personnel.

## General Specifications



### Heating specifications

#### Top Plate Surface – Solid Ceramic

Temperature range: 30°C – 450°C, 7" x 7"  
30°C – 400°C, 10" x 10"

	7" x 7"	10" x 10"
Heat-up time to maximum temperature (unloaded top plate)	5 minutes	7 minutes
Accuracy of the temperature display vs. the actual average temperature of a 2" diameter of setting area at the center of the top plate (set point 100°C unloaded)	± 5.0°C	± 5.0°C
<ul style="list-style-type: none"> <li>• Temperature stability at the center of the top plate surface (@ 100C unloaded)</li> </ul>	± 1.0°C	± 1.0°C
Accuracy of remote probe at user-selected calibration temperature after calibration procedure	± 5.0 typical	± 5.0 typical
<ul style="list-style-type: none"> <li>• Temperature stability using remote probe (500 ml of water in a 1000 ml flask at 70°C)</li> </ul>	± 5.0°C	± 5.0°C

#### Top Plate Surface – Solid Aluminum

Temperature range: 30°C – 300°C, 7" x 7"

See table on following page...

#### Electron Microscopy Sciences

P.O. Box 550  
1560 Industry Road Hatfield, PA 19440

Toll free: 1-800-523-5874

Tel: 215-412-8400

Fax: 215-412-8450

Web: [www.emsdiasum.com](http://www.emsdiasum.com)

Email: [sgkcck@aol.com](mailto:sgkcck@aol.com)

	<b>7" x 7"</b>
Heat-up time to maximum temperature (unloaded top plate)	5 minutes
Accuracy of the temperature display vs. the actual average temperature of a 2" diameter of setting area at the center of the top plate (set point 100°C unloaded)	± 5.0°C
<ul style="list-style-type: none"> <li>Temperature stability at the center of the top plate surface (@100°C unloaded)</li> </ul>	± 1.0°C
Accuracy of remote probe at user-selected calibration temperature after calibration procedure	± 5.0 typical
<ul style="list-style-type: none"> <li>Temperature stability using remote probe (500 ml of water in a 1000 ml flask at 70°C)</li> </ul>	± 5.0°C

*As the top plate becomes dirty, the maximum temperature will decrease. To return the unit to its maximum temperature performance, use a mild abrasive to remove stained areas.*

### Stirring speed specifications

Speed range 50 to 1500 RPM (maximum speed is dependent on the viscosity of the solution).  
Stability of the stirring speed set point (600 ml of water in a 1000 ml glass flask) ± 5.0% at 1000 RPM.

Top Plate Size	Max Recommended Flask Size	Max Weight on Top Plate
7 x 7	4 liters	25 pounds
10 x 10	6 liters	35 pounds

### Environmental conditions

**Operating**                    5°C to 35°C; 20% to 80% relative humidity, non-condensing. Installation category II (over voltage) in accordance with IEC 664. Pollution degree 2 in accordance with IEC 664. Altitude Limit: 2,000 meters.

**Storage**                     -25°C to 65°C. 10% to 85% relative humidity.

### Declaration of Conformity

Electron Microscopy Sciences declares under our responsibility that this product conforms to the technical requirements of the following standards:

EMC	EN 61000-3-2	Limits for harmonic current emissions
	EN 61000-3-3	Limits for voltage fluctuations and flicker
	EN 61326-1	Electrical equipment for measurement, control, and laboratory use (Part 1: General Requirements)
Safety	EN 61010-1	Safety requirements for electrical equipment for measurement, control, and laboratory use (Part 1: General Requirements)

**Electron Microscopy Sciences**  
P.O. Box 550  
1560 Industry Road Hatfield, PA 19440

Toll free: 1-800-523-5874

Tel: 215-412-8400

Fax: 215-412-8450

Web: [www.emsdiasum.com](http://www.emsdiasum.com)

Email: [sgkcck@aol.com](mailto:sgkcck@aol.com)

EN 61010-2-010	Part II: Particular requirements for laboratory equipment for the heating of materials
EN 61010-2-051	Part II: Particular requirements for laboratory equipment for mixing and stirring

*Per the provisions of the Electromagnetic Compatibility Directive 2014/30/EU, and per the provisions of the Low Voltage Directive 2014/35/EU. Copies of the Declaration of Conformity are available upon request.*

## Introduction to the SuperNuova™ Digital Top Stirring Plates

Thank you for buying the SuperNuova™ Digital Top Stirring Plate! Your hot plate, stirrer, or stirring hot plate is a heating and/or stirring plate that aids in various laboratory procedures that require precise control of temperature and/or stirring speeds.

Each unit includes a liquid crystal display for monitoring actual and setting temperature and/or stirring speed. The hot plate is able to produce accurately controlled top plate temperatures from 30°C to 300°C, 400°C or 450°C depending on your model type. The temperature can be controlled at the plate surface by an internal Type K thermocouple sensor, or the solution temperature may be controlled by utilizing the included PT100 probe. A PT1000 probe maybe be ordered separately by visiting us on the web at [www.emsdiasum.com](http://www.emsdiasum.com) or by calling Customer Service at 1-800-523-5874.

The 7 x 7 or 10 x 10 top plates on the SUPERNUOVA™ units are solid ceramic or solid aluminum, and are suitable for use with glass or metal vessels and sand baths.

Additional features:

- ✦ Time feature – heat shut off
- ✦ Temperature set points – program buttons
- ✦ Over temperature protection (OTP) – displayed in the system configuration menus

Applications:

- |                              |                       |
|------------------------------|-----------------------|
| ✦ General-purpose heating    | Digestions            |
| ✦ Sample preparation         | Media preparation     |
| ✦ Heating reagents           | Sterilization         |
| ✦ Melting paraffin           | Titrations            |
| ✦ Warming resinous chemicals | Sand baths            |
| ✦ Content analysis           | Micro-scale chemistry |
| ✦ Solvent evaporation        |                       |

### General cleaning instructions

1. Keep the top surface of the unit clean.
2. To clean the unit, use a non-abrasive cleaner.
3. If spills occur, unplug the unit and clean the spill immediately.
4. DO NOT immerse the unit for cleaning under any circumstances.
5. The exterior housing can be wiped clean with a damp cloth and mild soap.

**Electron Microscopy Sciences**  
P.O. Box 550  
1560 Industry Road Hatfield, PA 19440

Toll free: 1-800-523-5874  
Tel: 215-412-8400  
Fax: 215-412-8450

Web: [www.emsdiasum.com](http://www.emsdiasum.com)  
Email: [sgkcck@aol.com](mailto:sgkcck@aol.com)

## Unpacking and Installation



### Warning

- ✚ Use a properly grounded electrical outlet and the correct voltage
- ✚ DO NOT remove or modify grounded outlets – this avoids electrical shock
- ✚ DO NOT use near flammable sources – fire or explosion could occur
- ✚ This device contains materials that can ignite such sources
- ✚ DO NOT use in highly corrosive atmospheres – this could damage the top of the unit as well as its internal components



### Note

- ✚ Some of the parts of this unit may have been misaligned during shipment – prior to use, run the stirrer at maximum speed for 10 minutes to realign the bearings

### Unpacking

1. Remove the unit from its packaging and inspect to ensure there is no damage that has occurred during shipment.
2. If there is any visible damage to your unit, call Customer Service immediately at 1-800-523-5874.

The following items are included with the SUPERNUOVA™ unit. If any of the following are missing, contact Customer Service immediately.

- ✚ Cord
- ✚ Remote probe PT100
- ✚ Stir bar (stirring models only)
- ✚ Knob
- ✚ Instruction manual

### Installation

1. Set the unit on a flat surface away from any combustible source of any kind
2. Plug the cord set into a properly grounded electrical outlet

### SUPERNUOVA™ Hot Plate Control Panel

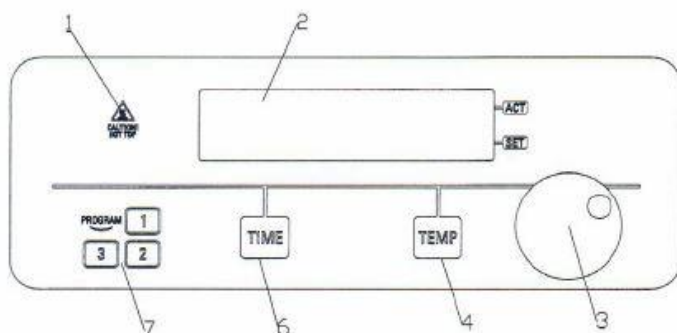

### Control panel legend

- |   |                            |
|---|----------------------------|
| 1 | CAUTION! HOT TOP Indicator |
| 2 | Display                    |
| 3 | Knob                       |
| 4 | Temperature set button     |
| 5 | Speed set button           |
| 6 | Time set button            |
| 7 | Program buttons            |

**Electron Microscopy Sciences**  
 P.O. Box 550  
 1560 Industry Road Hatfield, PA 19440

Toll free: 1-800-523-5874

Tel: 215-412-8400

Fax: 215-412-8450

Web: [www.emsdiasum.com](http://www.emsdiasum.com)

Email: [sgkcc@aol.com](mailto:sgkcc@aol.com)

### SUPERNUOVA™ Stirrer Control Panel

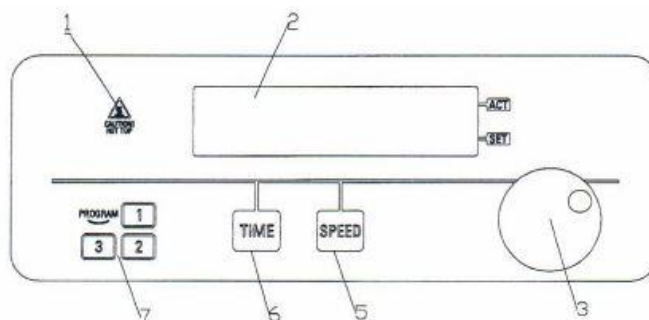

### SUPERNUOVA™ Stirring Hot Plate Control Panel

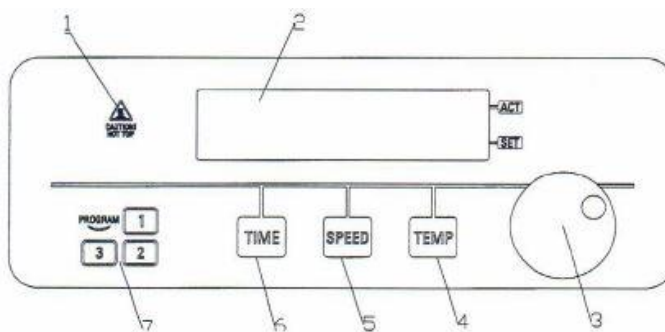

## Operation



### Warning

- ✦ Use extreme caution when heating volatile materials – the top of the unit surface as well as the element itself can reach “Flash Point Temperature” of many chemicals
- ✦ Hot plates are not explosion-proof – fire or explosion can occur
- ✦ The unit contains parts that can ignite such materials
- ✦ Appropriate protection when handling hazardous chemicals is strongly advised

“Caution: Hot Top. Avoid Contact.” The top plate of the unit will remain hot for some time after it is turned off and unplugged. A “CAUTION – HOT TOP” light will remain illuminated until the unit cools to a temperature below 50°C.

**Electron Microscopy Sciences**  
P.O. Box 550  
1560 Industry Road Hatfield, PA 19440

Toll free: 1-800-523-5874  
Tel: 215-412-8400  
Fax: 215-412-8450

Web: [www.emsdiasum.com](http://www.emsdiasum.com)  
Email: [sgkcck@aol.com](mailto:sgkcck@aol.com)





### Note

- ✦ Boiling times are dependent on the volume of the solution used as well as the surface area of the flask that is exposed to the hot plate
- ✦ The top plate temperature will be significantly higher than the solution temperature

### Hard Switch

The SUPERNUOVA™ unit has a hard switch on the left side of the unit.

To turn on the unit, press the hard switch. When the unit is on, it will initialize and the model name will be displayed on the first row of the display screen and the software version on the second.

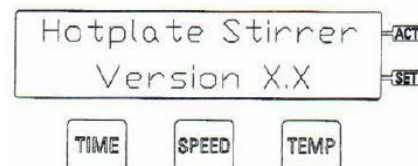

To turn the unit off, press the hard switch off.

### Setting the Stirring Speed

The SUPERNUOVA™ stirring unit has an electronic feedback speed control which maintains precise speed set points ranging from 50 rpm to 1500 rpm. The hot plates have strong magnets and high torque motor, drawing a vortex in fluids up to 700 cp.

To set the stirring speed:

1. Press "SPEED" key located under the display. The speed set point will then flash.
2. Use the knob on the front panel to set a speed.
3. Turn the knob clockwise to increase the speed. Turn the knob counterclockwise to decrease the speed.
4. Once you have reached your desired speed, press the "SPEED" key or wait 10 seconds and the set point will no longer flash, indicating that it is set.
5. Once the unit is stirring, the display will indicate both the actual speed and the set point.
6. To stop stirring without changing your adjusted set point, press the knob once.
7. To turn stirring off, press "SPEED" key under the display and turn the knob counterclockwise until it reads "OFF".



### Note

- ✦ Boiling times are dependent on the volume of the solution and the surface area of the flask that is exposed to the hot plate
- ✦ The top plate temperature will be higher than the temperature of your solution

### Setting the Temperature

The SUPERNUOVA™ unit has an electronic closed-loop feedback control which precisely maintains temperature set points from 30°C to 300°C, 400°C or 450°C, depending on the model.

**Electron Microscopy Sciences**  
P.O. Box 550  
1560 Industry Road Hatfield, PA 19440

Toll free: 1-800-523-5874  
Tel: 215-412-8400  
Fax: 215-412-8450

Web: [www.emsdiasum.com](http://www.emsdiasum.com)  
Email: [sgkcck@aol.com](mailto:sgkcck@aol.com)



An unloaded hot plate will heat to maximum temperature in just 5 minutes. A “CAUTION HOT TOP” light on the front panel will light up whenever the top surface temperature exceeds 50°C. The temperature can be controlled at the top plate by the internal Type K thermocouple sensor or in the solution using an accessory ungrounded PT 100 probe. If a probe is used, the display will indicate “R” after actual temperature.

SUPERNUOVA™ heating units are compatible with any ungrounded PT 100 (PT 1000) probe, however, the accuracy of probes other than those tested and specified may not reach the probe accuracy rating designated.

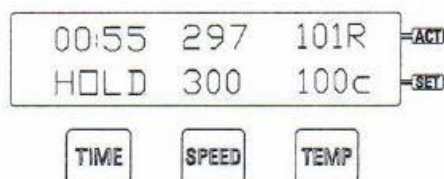

To set the temperature:

1. Press “TEMP” key located under the display. The temp set point will flash.
2. Use the knob on the front panel to select a temperature.
3. Turn the knob clockwise to increase the temperature.
4. To decrease the temperature, turn the knob counterclockwise.
5. When the desired set point is achieved, press the “TEMP” key or wait 10 seconds – when the flash stops illuminating, the temperature set point has been set.

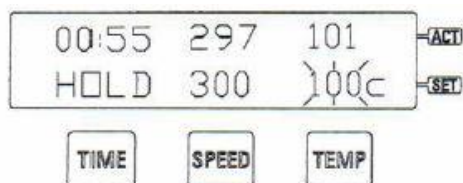

### Controlling Solution Temperature Using External Probe

To control the solution temperature:

1. Plug a PT 100 probe into the probe receptacle located on the back side of the unit.
2. Place the probe in the solution. The display will then indicate the actual temperature of the solution as it is measured by the probe.
3. The external probe offers more exact temperature control than regulating the top plate by the internal sensor. If you need to maintain a precise set point, we recommend using a probe to control the solution temperature instead of controlling it by the top plate temperature.
4. When using probes with the SUPERNUOVA™ unit, we recommend using a clamp on a support rod to hold the probe in the solution.
5. For accurate probe readings, be sure to immerse as much of the probe sheath as possible into the solution. Make sure that it is immersed in the solution and not outside of the solution or in the air. If the probe is plugged into the hot plate but is not in the solution while the heat control is operating, the temperature display will continue to indicate an ambient temperature and an error will occur. Because the set point cannot be reached, the heating element will continue to supply

**Electron Microscopy Sciences**  
P.O. Box 550  
1560 Industry Road Hatfield, PA 19440

Toll free: 1-800-523-5874  
Tel: 215-412-8400  
Fax: 215-412-8450

Web: [www.emsdiasum.com](http://www.emsdiasum.com)  
Email: [sgkcck@aol.com](mailto:sgkcck@aol.com)

heat to the top plate and the maximum top plate temperature (300°C, 400°C or 450°C) may be reached. If the remote probe does not indicate a temperature change, within three minutes the unit will display “ExProbe Err” and shut down.

### Using Preset Programs

The SUPERNUOVA™ unit has the ability to store up to 3 pre-set set points at a time. To program a preset:

1. Press any preset button and the indicated LED on the number button will light up.
2. Adjust the time, speed, and heat to your desired levels.
3. Press the number button again to exit the preset program.

The set points are stored in memory automatically, even if unplugged. The presets will only change if you override them.

To activate one of the presets:

1. Press the corresponding number and then the knob. The time, speed, and heat features will adjust automatically.

Preset Continue function also comes with this unit. Different presets can run continuously when Present Continue is being used. Default setting is reached when the function is turned off.

1. Press 1 and then press the knob. The unit will run by continuous presets by order 1, 2, 3.
2. The unit will run by continuous presets by order 2, 3 by selecting 2 and then pressing the knob.

### Heating Metal Vessels and Sand Baths

Heating metal vessels and sand baths cannot be performed on most solid ceramic tops due to the tendency of the metal and sand to reflect heat back into the top, exceeding maximum temperature. Due to its advanced features and technology, the SUPERNUOVA™ is able to regulate the top plate temperature.

### Setting the Time

The time function on the SUPERNUOVA™ unit can be adjusted to shut of heating features. To set the time:

1. Press “TIME” key located under the display. Hold will being to flash.
2. Turn the knob until the time shows, then press the “TIME” key again.
3. Use the knob on the front panel to select a desired time.
4. Turn the knob clockwise to increase the time or counterclockwise to decrease the time.
5. When the desired set point has been reached, press the “TIME” key or wait 10 seconds. The time set point will no longer flash, indicating that it has been set successfully.
6. In the temperature rising mode, when the temperature is more than 2 degrees below the temperature set point, the time will begin to count. In the temperature declining mode, on the other hand, when the temperature is less than 2 degrees above the temperature set point, the time will begin to count.

When the time set point display shows “HOLD” it signifies that there is not setting for time function.

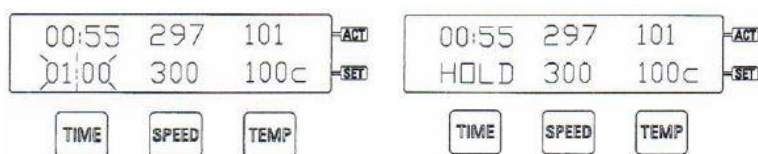

**Electron Microscopy Sciences**  
P.O. Box 550  
1560 Industry Road Hatfield, PA 19440

Toll free: 1-800-523-5874  
Tel: 215-412-8400  
Fax: 215-412-8450

Web: [www.emsdiasum.com](http://www.emsdiasum.com)  
Email: [sgkcck@aol.com](mailto:sgkcck@aol.com)

## Hardware Over-Temperature-Protection

OTP analog circuits are designed separately with the responsibility of protecting unexpected heating. A small straight blade screwdriver can be used to adjust the scale at the ride side of the unit, if needed. The protection value can be set from 60°C to 500°C.

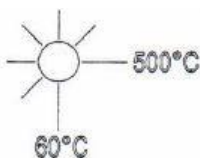

Please note that this function is ONLY used to avoid abnormal or unwanted heating, especially if the unit is not operating properly. Authorized personnel SHOULD NOT use this function to limit the temperature in normal applications. The default set is at maximum scale.

## Hardware Over-Temperature-Protection

The system configuration has three features that will allow authorized personnel using this unit to customize it to their application needs.

The features shown in the table below are displayed in order of their appearance in the system configuration when rotating the knob clockwise. The feature column is the name of the feature, the display column is the designation of that feature as shown on the display of the unit, the availability column shows the type of unit the feature is application (HP = hot plate, SP = stirring hot plate, S = stir plate), and the last column gives a brief description of the purpose of the feature.

Feature	Display	Availability	Brief Description
Temperature Unit Conversion Over-temperature Set Point	Temp Unit	HP , SP	Allows the user to converse temperature unit between °C and F.
Over-temperature Set Point	User OTP	HP , SP	Allows the user to see the setting of the Over Temperature Protection control.
Preset Continue Setting	Preset Continue	HP , S, SP	Allows the user to set the program presetting function.
Temperature Probe Calibration	Calibrate Temp	HP , SP	Allows calibration of the temperature probe and associated circuitry.

**Electron Microscopy Sciences**  
P.O. Box 550  
1560 Industry Road Hatfield, PA 19440

Toll free: 1-800-523-5874

Tel: 215-412-8400

Fax: 215-412-8450

Web: [www.emsdiasum.com](http://www.emsdiasum.com)

Email: [sgkcck@aol.com](mailto:sgkcck@aol.com)

## Temperature Unit

The temperature unit option is only available for units with a heating function.

1. Plug the unit into the appropriate power source.
2. Enter the system configuration by pressing and holding the knob.
3. After about 5 seconds, remove your finger from the knob. The display will indicate "System Config" on the first row, and "Temp Unit" on the second.

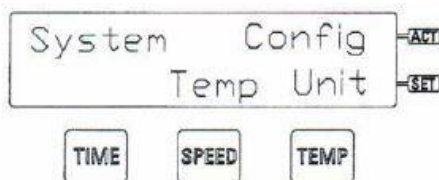

4. Press the knob to enter the Temp Unit setting interface (a long press will return to the operation menu). The "Temp Unit" will display on the first row, the actual temperature and unit "C" or "F" on the second row.
5. Turn the knob clockwise or counterclockwise to change the temperature.
6. When the desired temperature has been reached, wait 10 seconds. The display will return to operating menu indicating successful set of temperature.

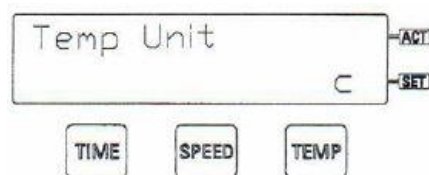

## Over-temperature Set Point – OTP

This option is only available for units with heating function. The OTP is the set point of the independent temperature control. This feature serves to limit the top temperature of the element of the standard heating control. This comes in handy when a failure of the main control occurs, which would cause excessive top heat. Typically, the set point can be adjusted from 60°C to 300°C, 400°C or 450°C.

The OTP can be set or viewed with this menu option. To do so:

1. Enter the system configuration by pressing and holding the knob.
2. After about 5 seconds, release your finger from the knob.
3. The display will indicate "system config" on the first row, and "temp unit" on the second.
4. Turn the knob clockwise until the "User OTP" shows on the second row of the display. If you do nothing, the display will return to the operation status.

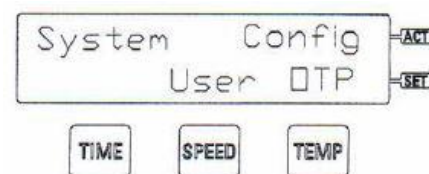

**Electron Microscopy Sciences**  
P.O. Box 550  
1560 Industry Road Hatfield, PA 19440

Toll free: 1-800-523-5874  
Tel: 215-412-8400  
Fax: 215-412-8450

Web: [www.emsdiasum.com](http://www.emsdiasum.com)  
Email: [sgkcck@aol.com](mailto:sgkcck@aol.com)

5. Press the knob to enter the OTP setting interface (a long press will return to the operation menu). The “User OTP” will be displayed on the first row and the OTP set point flash on the second.
6. Turn the knob clockwise to increase the temperature or counterclockwise to decrease the temperature.
7. Once your desired temperature is reached, wait 10 seconds, and the display will return to the operation menu.

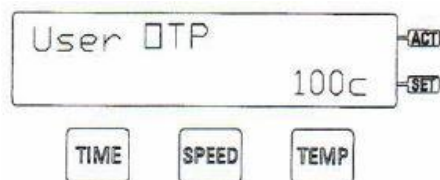

### Preset Continue

1. Enter the system configuration by pressing and holding the knob.
2. After about 5 seconds, release.
3. The display will indicate “system config” on the first row and “temp unit” on the second.
4. Turn the knob clockwise until the “present continue” shows on the second row on the display. If you do nothing, the display will return to the operation status.

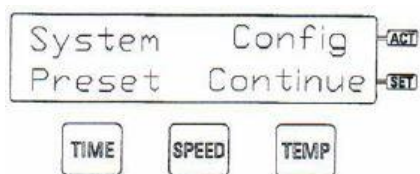

5. Press the knob to enter the Preset Continue setting interface (a long press will return to the operation menu). The “User OTP” will show on the first row, “OFF” on the second.
6. Turn the knob clockwise to change the status. When “on” has reached, wait 10 seconds, then the display will return to the operation menu.



### Temperature Probe Calibration

This section is only applicable to the calibration of the temperature probe system. The hot plate surface and the motor speed CANNOT be calibrated. This method is only applicable to units that have heating function.

1. Enter the system configuration by pressing and holding the knob.
2. After 5 seconds, release.
3. “System config” will be displayed on the first row, and “Temp Unit” on the second.
4. Turn the knob clockwise until the “Calibrate Temp” shows on the second row of the display.

**Electron Microscopy Sciences**  
P.O. Box 550  
1560 Industry Road Hatfield, PA 19440

Toll free: 1-800-523-5874

Tel: 215-412-8400

Fax: 215-412-8450

Web: [www.emsdiasum.com](http://www.emsdiasum.com)

Email: [sgkcck@aol.com](mailto:sgkcck@aol.com)

5. The option “Calibrate Temp” will ONLY show when there is a remote probe PT 100 or PT 1000 adopted.

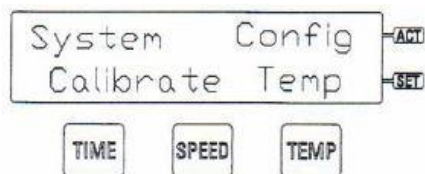

6. Press the knob to enter the Calibrate Temp setting interface. The “Calibrate Temp” will show on the first row, and the measured temperature flash on the second. When setting and/or viewing is complete, the knob can be pressed to return to the previous operation menu.



## Troubleshooting



### Error Codes

See next page.

**Electron Microscopy Sciences**  
P.O. Box 550  
1560 Industry Road Hatfield, PA 19440

Toll free: 1-800-523-5874

Tel: 215-412-8400

Fax: 215-412-8450

Web: [www.emsdiasum.com](http://www.emsdiasum.com)

Email: [sgkcck@aol.com](mailto:sgkcck@aol.com)



Displayed Message	Intended to Detect	Cause	Solution
InProbe Err	Internal thermocouple out of range.	Internal thermocouple not connected. Thermocouple open. Thermocouple connected backwards (reversed polarity).	Ensure proper connection and polarity of thermocouple. Replace thermocouple (attached to element). Ensure proper connection and polarity.
Check Heater	Excessive top heat-up time	Internal thermocouple short circuit. Failure in Internal thermocouple. Failure in Element. Failure in optocoupler/triac circuit.	Remove short. Replace thermocouple (attached to element). Replace Element. Replace Control Board.
ExProbe Err	External Probe left out of solution.	External Probe left out of solution. External probe connected backwards.	Place external probe into solution. Correct orientation of external probe.
Over Temp	OTP thermocouple out of range.	OTP Circuit failure. OTP potentiometer set too low.	Replace Control Board. Increase OTP setting.
Check Motor	Motor system failure.	Locked rotor condition. Failure of motor. Failure of motor circuit. Failure of motor sensor.	Free locked rotor. Replace motor. Replace Control Board. Replace motor sensor.

**Electron Microscopy Sciences**  
P.O. Box 550  
1560 Industry Road Hatfield, PA 19440

Toll free: 1-800-523-5874  
Tel: 215-412-8400  
Fax: 215-412-8450

Web: [www.emsdiasum.com](http://www.emsdiasum.com)  
Email: [sgkcck@aol.com](mailto:sgkcck@aol.com)





For any questions or for ordering information, please  
contact Customer Service at 1-800-523-5874.

*Thank you for choosing Electron Microscopy Sciences!*

**Electron Microscopy Sciences**  
P.O. Box 550  
1560 Industry Road Hatfield, PA 19440

Toll free: 1-800-523-5874

Tel: 215-412-8400

Fax: 215-412-8450

Web: [www.emsdiasum.com](http://www.emsdiasum.com)

Email: [sgkcck@aol.com](mailto:sgkcck@aol.com)