

**INSTRUCTIONAL MANUAL
CAT. 71260-10 through 71260-17**

**Cabinet Style Lab Companion™
Vacuum Desiccators**



Safety Symbols Defined

Please read and follow all instructions and safety notices thoroughly before using the Cabinet Style Lab Companion™ Vacuum Desiccators. The following safety symbols are used throughout this Manual:

DANGER

This alert could cause serious or fatal injury if ignored.

CAUTION

This alert could cause serious injury or property damage if ignored.

NOTICE

This alert could cause operational problems if ignored.

DANGER

Ignoring these alerts could cause serious or fatal injury.

- Never install or use this unit in explosive atmospheres.
- Never install this unit near flammable or hazardous substances.
- Never disassemble, modify or repair this unit on your own. Doing so will void the warranty and may result in injuries or product damage.

CAUTION

Ignoring these alerts could cause serious injury or property damage.

- Read carefully all the warning labels on the unit.
- DO NOT remove or damage the warnings labels on the unit.
- ALWAYS use the molded-in handles to move unit.
- DO NOT move unit while in operation.
- DO NOT use unit in moist or wet atmosphere or where water leakage may occur.
- DO NOT place or store unit in direct sunlight or near any other heat sources.
- DO NOT use unit where metallic dust exists or in contaminated atmosphere.
- DO NOT expose inside of unit to organic solvents, corrosives gases, or moisture.
- DO NOT use chlorine bleach, ammonia, ammonia-based cleaners, abrasives or metal scouring pads to clean unit.
- Use only a clean, soft, damp cloth or a sponge soaked in a dilute, neutral detergent or water to clean unit.

Unpacking Desiccator

Inspect the package and unit for any damage that may have occurred during shipping. Notify the carrier immediately if any damage has occurred. DO NOT use if damage has occurred. Also, check to make sure all items listed below are included. If any are missing, please call Customer Service right away at 1.800. 523-5874.

1 – Cabinet Unit	Port Plug
1 – Vacuum Gauge	Perforated Shelves
1 – 3-Way Valve	
1 – Door Seal	
1 – Desiccant Tray	
1 – User Manual	

Introduction & Features

Thank you for purchasing a Cabinet Style Lab Companion™ Vacuum Desiccator. This unit is specially designed for high-performance, safety, ease-of-use and long-lasting durability. There are eight models to choose from; 11, 23, 35, and 45 liter internal volume in clear or UV blocking amber. All models feature:

- Vacuum sustainment of 1 Torr (133 Pa) vacuum for more than 72 hours at room temperature; stays gas-tight without a vacuum, allowing for reliable experiments over longer periods.
- the unique, unibody construction is a single molded piece (except for door) allows for maximum vacuum retention
- The polycarbonate body is shock-resistant, has a high tensile strength and, with a 360° transparent view, allows visual observation for any angle.
- The airtight door is equipped with a special latch that is easy to close under normal pressure and a greaseless vacuum seal that uses a high-quality silicon gasket that allows for quick airtight sealing and vacuum pressure.
- The 3-way valve that comes with the unit performs consistently with a uniform vacuum draw, vacuum release or gas exchange without having to connect/disconnect pump hoses. Up to four valves can be installed, with valve positioning being easily changes.
- Since all the units in the series have the same footprint, they are stackable to save lab space.
- Another space-saving feature is that the cabinet desiccators, being rectangular have a larger usable volume than round desiccators.
- Depending on unit size, up to 4-6 shelves can be used. (Depending on sized ordered, 2-3 shelves are included.)
- Accurate, built-in gauges are installed on the front door for ease of checking vacuum levels.
- A desiccant tray is also included.

Cabinet Desiccator Diagrams

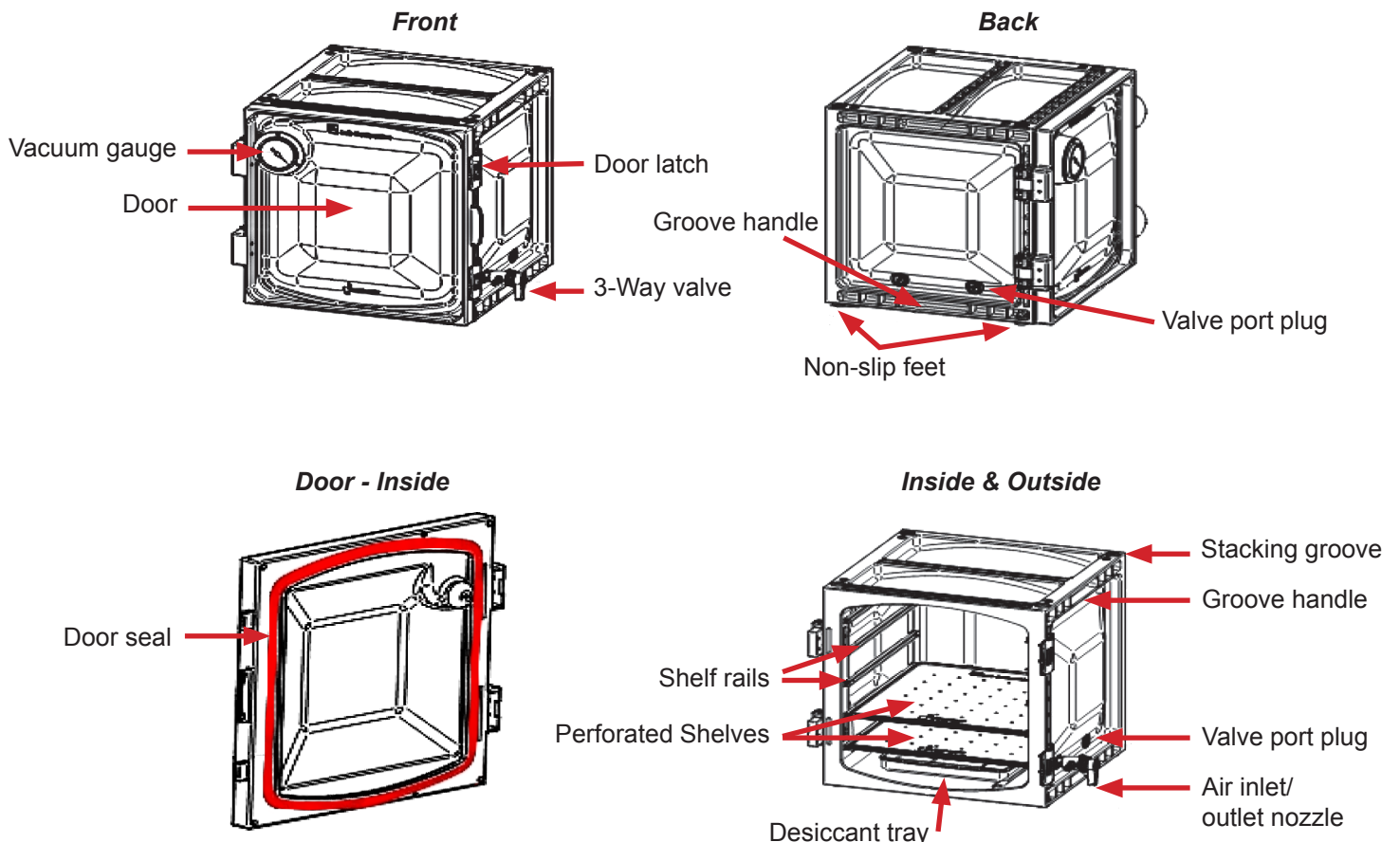

Applications

The Cabinet Style Lab Companion™ Vacuum Desiccator is designed to be used in many applications. It is ideal for:

- Removing residual solvents or air bubbles
- Conducting low pressure experiment
- Cultivating anaerobic microbes
- Storing moisture-sensitive material such as anhydrides and other hygroscopic compounds as well as materials which are highly reactive with atmosphere
- Low pressure drying, which minimizes heat effect
- Drying/cooling stages of biological/materials/food/medical experiments where minimal air exposure and/or re-absorption of humidity is needed

Placing and Moving the Desiccator

NOTICE DO NOT expose unit to any heat source including direct sunlight.

This unit is designed for indoor laboratory use only, under the following conditions:

- Ambient Temperature range: 5 to 40°C (41 to 104°F)
- Relative humidity: < 80%
- Altitude: 0 to 2,000m (6,562 ft.)
- Unit must be placed on a level surface.
- Unit must be at least 30 cm (approx. 3 ft.) away from other equipment
- When relocating the unit, use the built-in groove handles instead of holding on to other protruded parts such as the vacuum gauge or 3-Way valves

Operating Conditions

- DO NOT form a vacuum when airtight containers are inside the unit.
- DO NOT autoclave this unit.
- When removing the port plug(s) in order to attach other equipment or additional 3-way valves, be sure use proper O-rings and nuts for tight sealing.
- DO NOT place high-temperature samples inside the unit. First, cool them thoroughly or DO NOT place them in direct contact with the interior of the unit, in order to avoid any damage to the interior.

3-Way Valve Open/Closed Positions

When the handle aligns to a nozzle, that nozzle is open and the other nozzle is closed. When the handle is perpendicular (vertical) to both nozzles, both nozzles are closed.

When facing the front of the desiccator, the 3-way valve is on the right side of the unit and, in the diagrams below, the nozzle closest to the front of the unit is labeled "Front" and the nozzle towards the back of the unit is labeled "Rear".

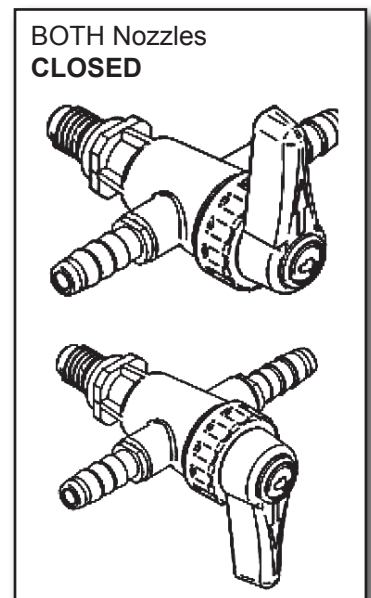
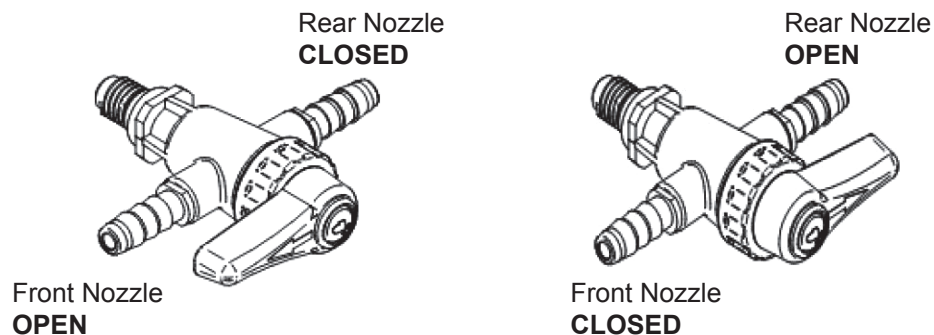

Potential Hazards

- Moisture and chemicals from the samples may result in damages to the pump.
- When the unit is not forming a vacuum, keep the valve handle perpendicular to the nozzles
- The body of the unit will be damaged if there is direct contact with acetone, benzene, toluene, chloroform, cresol, sodium hydroxide, highly concentrated nitric or sulfuric acid, acetic acids, or strong chlorine-based solvents
- Strong acids or bases will also destroy the door seal, thereby causing malfunction of the unit.

Directions for Vacuum Formation

CAUTIONS





Ignoring these alerts could cause serious injury or property damage.

- When forming or releasing a vacuum, turn the valve handle slowly to avoid rapid pressure change. If not, the stored samples can be damaged or dispersed
 - When a vacuum is formed inside the unit, do not apply excessive force to the 3- way valves, the vacuum gauge, or any of their vicinities. Any damages caused by external forces can cause malfunction of the unit.
 - DO NOT impact or drop the unit when a vacuum is formed inside.
1. When using the unit for drying purposes, fill the tray with desiccants and put it inside prior to operation.
 2. Place samples inside the unit, firmly close the door by properly locking both latches. There will be an audible “click” sound when the latch is properly engaged.
 3. Install a cold trap in front of the vacuum pump before forming a vacuum.
 4. Connect the vacuum pump hose to one of the two nozzles of the 3-Way valve.
 5. After vacuum pump activation, turn the valve handle towards the nozzle to open it; read the vacuum gauge to check whether the vacuum is forming properly.
 6. Once pre-determined vacuum level is reached, turn the valve handle until it is perpendicular to the nozzle to close it and check the vacuum gauge whether there is any leakage.
 7. To release the vacuum and return to normal atmosphere, slowly turn the valve handle towards the opposite nozzle.

Trouble Shooting Guide for Vacuum Malfunction

CAUSE	CORRECTIVE ACTION
Contaminated surface between door and body	Thoroughly clean the surface with a soft cloth using diluted neutral detergent.
Damaged door gasket	Replace the gasket
Unsuitable room temperature	Check to see if the temperature is within the operating range.
Misplaced or damaged 3-way valve	Check to see if the valve is properly set. If damaged, replace it with a new one.
Damaged vacuum gauge	Replace the gauge.

Technical Specifications

		 71260-10 71260-11	 71260-12 71260-13	 71260-14 71260-15	 71260-16 71260-17
Internal Volume		11 L	23 L	35 L	45 L
Material	Body/Shelves	Polycarbonate (PC)			
	3-Way Valve, Latch, Desiccant Tray	Polypropylene (PP)			
	Vacuum Gasket	Silicone			
Vacuum	Gauge Range	Analog 0 ~ -0.1 MPa			
	Max. Permissible	1.33 x 10 ⁻⁴ 1Torr			
	Nozzle Diameter	0.95 mm			
Dimension	Overall (W x D x H)	322 x 285 x 271 mm	420 x 397 x 281 mm	420 x 397 x 381 mm	420 x 397 x 491 mm
	Door opening (W x H)	208 x 238 mm	295 x 245 mm	295 x 345 mm	295 x 445 mm
	Shelf (W x D x H)	202 x 204 x 6.5 mm		289 x 304 x 11 mm	
	Desiccant Tray (W x D x H)	158 x 194 x 24 mm		218 x 268 x 268 mm	
	Net Weight	4.2 kg	8.2 kg	10.8 kg	12.2 kg
Shelves	Number of Shelves (Standard/Maximum)	2/4		3/5	3/6
	Max. Load/Shelf (kg)	3	5		
UV Protection Range for the AMBER desiccators only		UV A,B,C 100% (200~450nm)			



Maintenance

CAUTIONS

- DO NOT use chlorine bleach, ammonia-based cleaners, abrasives, organic solvents, or metal scouring pads when cleaning. Always use a soft cloth.
- If the unit is contaminated, wear chemicals-resistant gloves before cleaning.
- Regularly check the 3-way valves, the vacuum gauge, or any of their vicinities for any damage.
- Regularly check the vacuum seal and the surface where the body and the base are in contact and keep them always clean and undamaged.
- Make sure to clean the silicone gasket regularly using diluted neutral detergent. For thorough cleaning, detach the seal from the lid.



Stacking Units

The cubic vacuum desiccators are designed to be easily multi-stacked together by locking the feet of the unit into the stacking grooves located on the top surface of another unit.



Storage

If this unit is not to be used for an extended period of time, clean it with soft cloth, pack it for extra protection and store it in dry place.



Disposing of Unit

Disposing of the unit must be done in an environmentally responsible way if it has been potentially exposed to bio-agents or radioactive samples. Failure to follow stringent requirements for appropriate disposal may lead to actions against you and your organization. Follow the policies/procedures of your laboratory or organization for disposal of laboratory equipments and wastes. If necessary, contact local governing body for regulations regarding disposal of laboratory equipment.

**Electron
Microscopy
Sciences**

For any questions or for ordering information,
please contact Customer Service at
1-800-523-5874

Thank you for choosing
Electron Microscopy Sciences!

www.emsdiasum.com
sgkcck@aol.com

Tel: 215-412-8400 ♦ *Fax:* 215-412-8450

Electron Microscopy Sciences
P.O. Box 550
1560 Industry Road
Hatfield, PA 19440