

**INSTRUCTIONAL MANUAL
CAT. 62057-10
Frigimat® Cub – Dry Ice Maker**



Safety Symbols Used in this Instruction Manual

Please read and follow all safety precautions and directions as outlined in this instruction manual before using this product.

The symbols used in this manual are:



Must wear insulated safety gloves



Must wear safety goggles

Recommended Safety Equipment to Wear & Warnings



WARNING:



- Always wear safety glasses and insulated gloves because of the pressures and temperatures that are used when working with liquid and/or solid carbon dioxide (CO₂).
- DO NOT tamper with the relief valve that extends from the brass fitting. **NOTE:** relief valve set at 12 psi.
- **NOTE:** For convenience, the pressure gauge can be rotated in almost any direction. To allow for this, the gauge mounting is normal loose and will not cause a leak.

Introduction

In only a few minutes, this compact device can be attached to a liquid CO₂ cylinder and will produce a ready-to-use 250 – 300 gram block of dry ice. (Each 50 lb. cylinder makes from 10 to 16 blocks of dry ice). Set-up and use is safe and simple. Dry ice production can be viewed through the transparent polycarbonate body that secures without clamps or screws or tools ensuring easy removal of the solid block of dry ice and connection from the CO₂ cylinder. A rugged nickel plated “pigtail” connects the Frigimat® Cub – Dry Ice Maker to the CO₂ cylinder valve. The system operates at very low pressure (displayed on the built-in dial gauge) and incorporates multiple pressure relief safeguards.

The body of the FRIGIMAT® Cub – Dry Ice Maker is molded of polycarbonate plastic. The polycarbonate plastic can be damaged by crazing (hairline cracks), caused by chemicals and their vapors. This weakens the dry ice maker and may result in explosion under pressure. **NOTE: Before each use**, inspect the product for any cracking or damage. Clean only with mild detergent and water and then air dry.

The bottom half of the dry ice maker includes a neoprene safety strap with attached lanyard. In order to produce a dry ice block, this strap must be used to secure the top and bottom halves together. Regularly check the Neoprene strap for damage or cracks

NOTE: The best type of cylinder to use with this product is one equipped with a dip tube. This allows for the cylinder to be upright. If your supplier does not carry this type of cylinder, you can use it by laying the “standard” cylinder on its side with the valve lower than the cylinder.

How the FRIGIMAT® Cub Dry Ice is Produced

The FRIGIMAT® Cub – Dry Ice Make utilizes the Joule-Thomson effect to produce solid CO₂ from liquid CO₂.

1. The CO₂ enters the cavity through an orifice and vaporizes at essentially atmospheric pressure.
2. The chamber is cooled by the vaporizing CO₂.
3. Both the incoming CO₂ and the dry ice maker are continuously chilled until a temperature is reached at which point the incoming CO₂ is directly converted to hard-packed carbon dioxide snow.
4. As more CO₂ is frozen, the snow is compressed inside the chamber to produce the solid dry ice cake.

Assembly Instructions

NOTE: The “Pigtail” is the long metal tubing with fittings on either end.

1. Attach one end of the “pigtail” to the threaded end of the brass fitting assembly and thread the other end onto the cylinder control valve of the Liquid Carbon Dioxide (LCO₂) cylinder with dip tube.
2. Place the bottom half of the dry ice maker body on a flat surface. **NOTE:** The neoprene strap with lanyard is attached to the bottom half.
3. Place the entire brass fitting assembly into its holding bracket on the bottom half of the dry ice maker body with the pressure gauge extending upward and the fitting with pigtail pointing outward. Ensure that fitting with O-ring seal is seated properly in groove in the dry ice maker body.
4. Place the top half of the body onto the bottom half, engaging and trapping the brass fitting with O-ring seal.
5. Hook the Neoprene strap onto the cleat: Hold both the top and bottom halves of the body together on a firm surface and pull upward on the lanyard to stretch the Neoprene strap up and over the top half of the dry ice maker body and down the opposite side to hook the Neoprene strap onto the cleat on the bottom half. Be sure the Neoprene strap is completely held by and centered on the cleat.
6. Stretch the Neoprene strap into the mold-in slots across each side of the top half of the dry ice maker body.

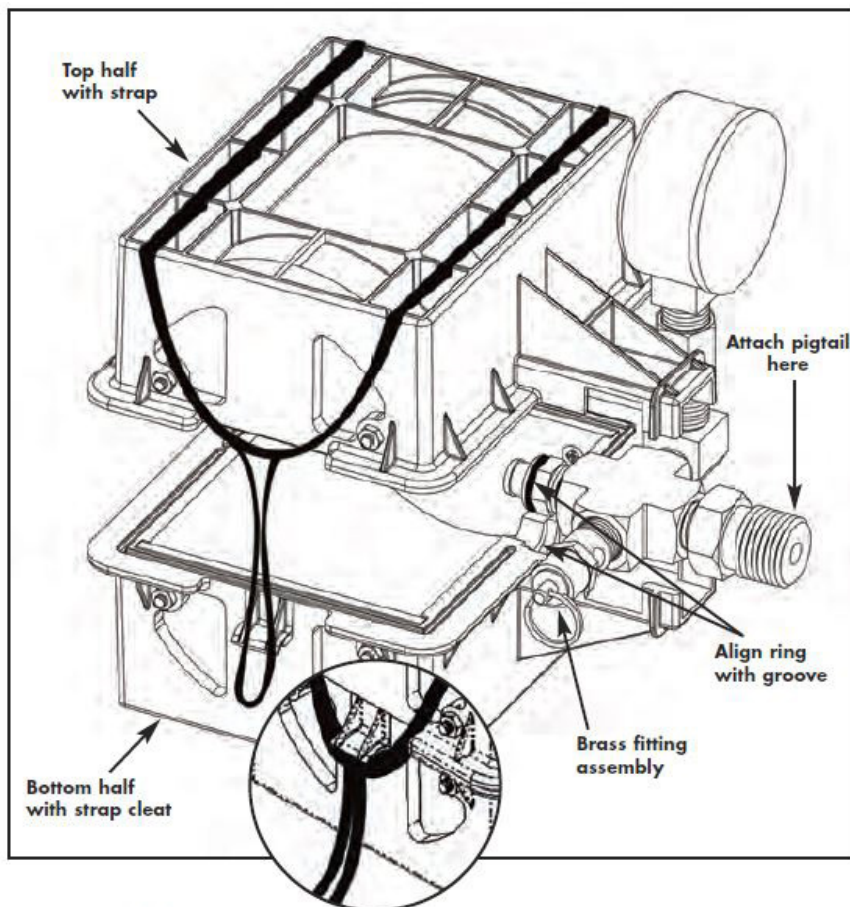

Operational Instructions

WARNING: Do not operate the FRIGIMAT® Cub – Dry Ice Maker unattended.

7. Open the cylinder valve very slightly to start the LCO₂ flow.
 8. Maintain the pressure at or below 1 psi (ONE psi) above the resting pressure on the outer scale of the gauge. **NOTE:** It is normal to see some CO₂ vapors leaking from the seams and to hear the sound of the CO₂ flowing. Since the body of the unit is transparent, the CO₂ ice formation and chamber capacity can be monitored. The dry ice block is fully formed when the pressure reading on the gauge rises rapidly and the sound of the gas flow becomes louder. Close the cylinder valve. It takes approximately 4-5 minutes to make each ice block.
 9. To remove the dry ice from the dry ice maker:
 - a. Release Neoprene strap from the cleat and allow it to retract.
 - b. Remove top half of the body to expose the dry ice block.
 - c. Remove brass fitting with pigtail assembly.
 - d. Invert bottom half of the body to release the dry ice block.
- NOTE:** The weight of dry ice block will be approximately 250 to 300 gm.
10. If making a second block, allow time for frost or ice to dissipate from the brass fitting and body of the FRIGIMAT® Cub – Dry Ice Maker. **NOTE:** Frost build-up can prevent unit from closing.

Liquid Content Variation in CO₂

- When CO₂ cylinders are filled with gas, the cylinder pressure is maintained at between 700 and 850 psi, at which about 30% of the cylinder volume is filled with gas while the remainder contains liquid.
- The Frigmat® Dry Ice Maker will produce dry ice only from liquid CO₂. The amount of dry ice which can be made is a function of the amount of liquid present in the cylinder. This in turn, is a function of the temperature of the cylinder.
- A cooler cylinder contains more liquid and thus can produce more dry ice. As the chart below indicates, liquid weight is reduced at higher temperatures:
 - At 60°F (15.6°C) liquid content is about 77%
 - At 70°F (21°C) liquid content is about 70%
 - At 80°F (26.7°C) liquid content is about 58%

NOTE: Above 88°F (31°C), the critical temperature, dry ice cannot be made and only gas is present.

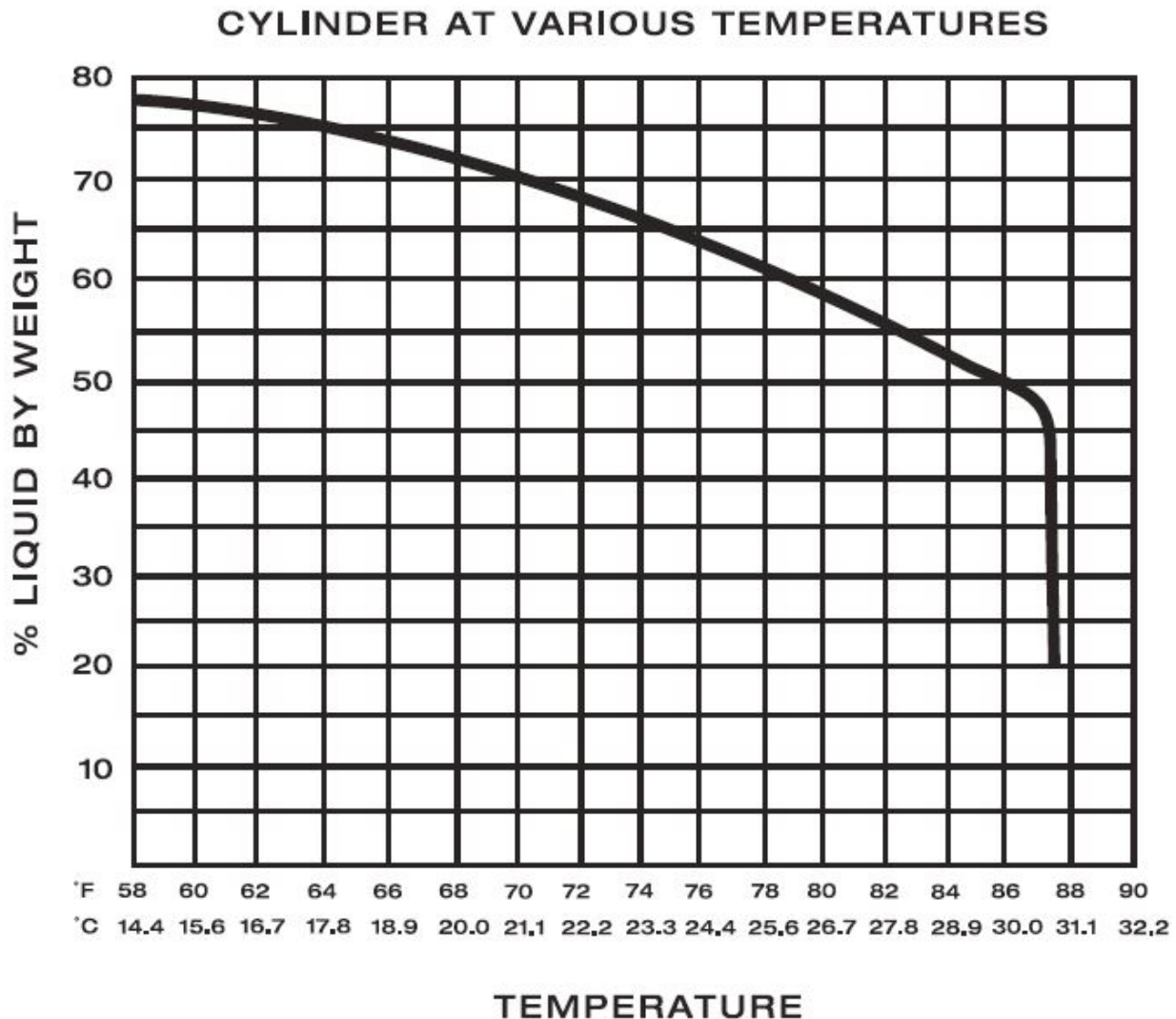

**Electron
Microscopy
Sciences**

For any questions or for ordering information,
please contact Customer Service at
1-800-523-5874

Thank you for choosing
Electron Microscopy Sciences!

www.emsdiasum.com
sgkcck@aol.com

Tel: 215-412-8400 ♦ *Fax:* 215-412-8450

Electron Microscopy Sciences
P.O. Box 550
1560 Industry Road, Hatfield, PA 19440